

BR-1614 Series

LED Architectural Bollard

Type:

Catalog Number:

Project/Location:

Approved By:

SPECIFICATIONS

Housing: Heavy-duty construction of corrosion resistant extruded aluminum. Stainless steel hardware.

Gasket: Closed cell silicone foam gasket. Seals out moisture, dust, and insects for weather-tight operation.

Mounting: Secures with 3/8" x 6" galvanized anchor bolts.

Lens: 1/8" thick UV stabilized 2447 white acrylic.

Access: Top access for driver and LED.

Driver: Constant current and Universal input voltage 120-277V, 50-60Hz line voltage frequency. Operating temperature -20°C to 40°C, Power Factor \geq .90.

LED: Specify amber (A), blue (B), green (G), red (R), or 3000 (30K), 3500 (35K), 4000 (40K), and 5000K (50K). 40K Standard.

Lumens: 3100.

Distribution: Type III, Type IV, Type V.

Finish/Colors: Zinc based primer with polyester powder coat finish in Matte Black (MB), Matte White (MW), Matte Bronze (BZ), Silver Gray (SG), or a custom color (CC).

Testing: LM79, LM80, ETL.

Conforms to UL Standard 1598. Suitable for wet locations.

See options page for additional information or consult factory.



Series	Source	Wattage/Max
BR-1614	LED	40W

ORDERING EXAMPLE

BR-1614 – 40WLED – 40K – III – UNV – SCBA



To fit on existing, or shaft by others.

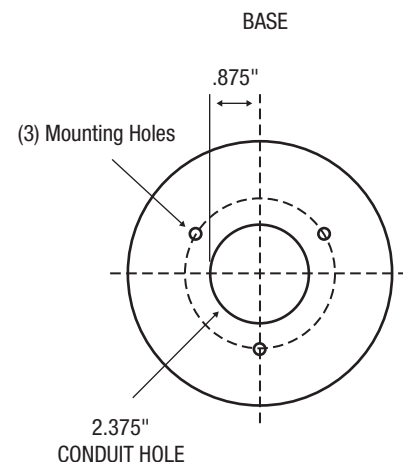
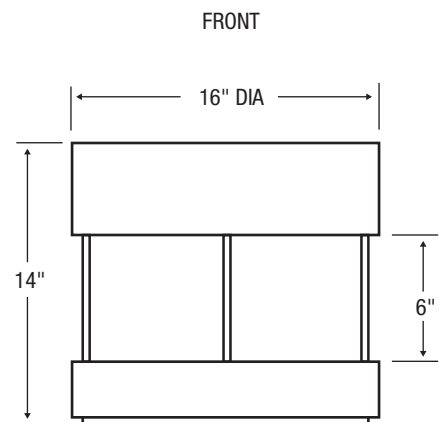

ELCAST LIGHTING

815 S. Kay Ave., Addison, IL 60101 USA • 630.543.5390
www.ElcastLtg.com • ElcastLtg@ElcastLtg.com

Made in USA – 5 year limited warranty

©2017. Specifications are subject to change without notice. Consult factory for verification.

REV 05-24