

LBA-16 Series

LED Architectural Interior

Type:

Catalog Number:

Project/Location:

Approved By:



SPECIFICATIONS

Housing: Heavy-duty construction of die cast and spun aluminum.

Gasket: Closed cell silicone foam gasket. Seals out moisture, dust and insects for weather-tight operation.

Mounting: Pendant mount with 10' stainless steel cable or ceiling mount over standard J-box.

Lens: One piece molded UV stabilized acrylic lens.

Driver: Constant current and Universal input voltage 120-277V, 50-60Hz line voltage frequency. Operating temperature -20°C to 40°C, Power Factor $\geq .90$.

LED: Specify 3000 (30K), 3500 (35K), 4000 (40K), and 5000K (50K). 30K Standard.

Lumens: 4000.

Finish/Colors: Zinc based primer with polyester powder coat finish in Matte Black (MB), Matte White (MW), Matte Bronze (BZ), Silver Gray (SG), or a custom color (CC).

Testing: LM79, LM80, ETL.

See options page for additional information or consult factory.



EMERGENCY BATTERY
BACKUP AVAILABLE

Series	Source	Max Wattage
LBA-16	LED	21W

ORDERING EXAMPLE

LBA-16 – 56WLED – 3K – 120 – SG

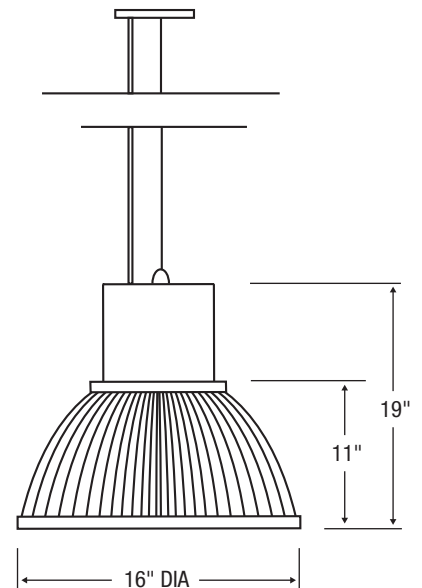

ELCAST LIGHTING

815 S. Kay Ave., Addison, IL 60101 USA • 630.543.5390
www.ElcastLtg.com • ElcastLtg@ElcastLtg.com

Made in USA – 5 year limited warranty

©2017. Specifications are subject to change without notice. Consult factory for verification.

REV 05-24